

# Lab on a Chip

Miniaturisation for chemistry, physics, biology, materials science and bioengineering

[www.rsc.org/loc](http://www.rsc.org/loc)

Volume 12 | Number 22 | 21 November 2012 | Pages 4583–4930

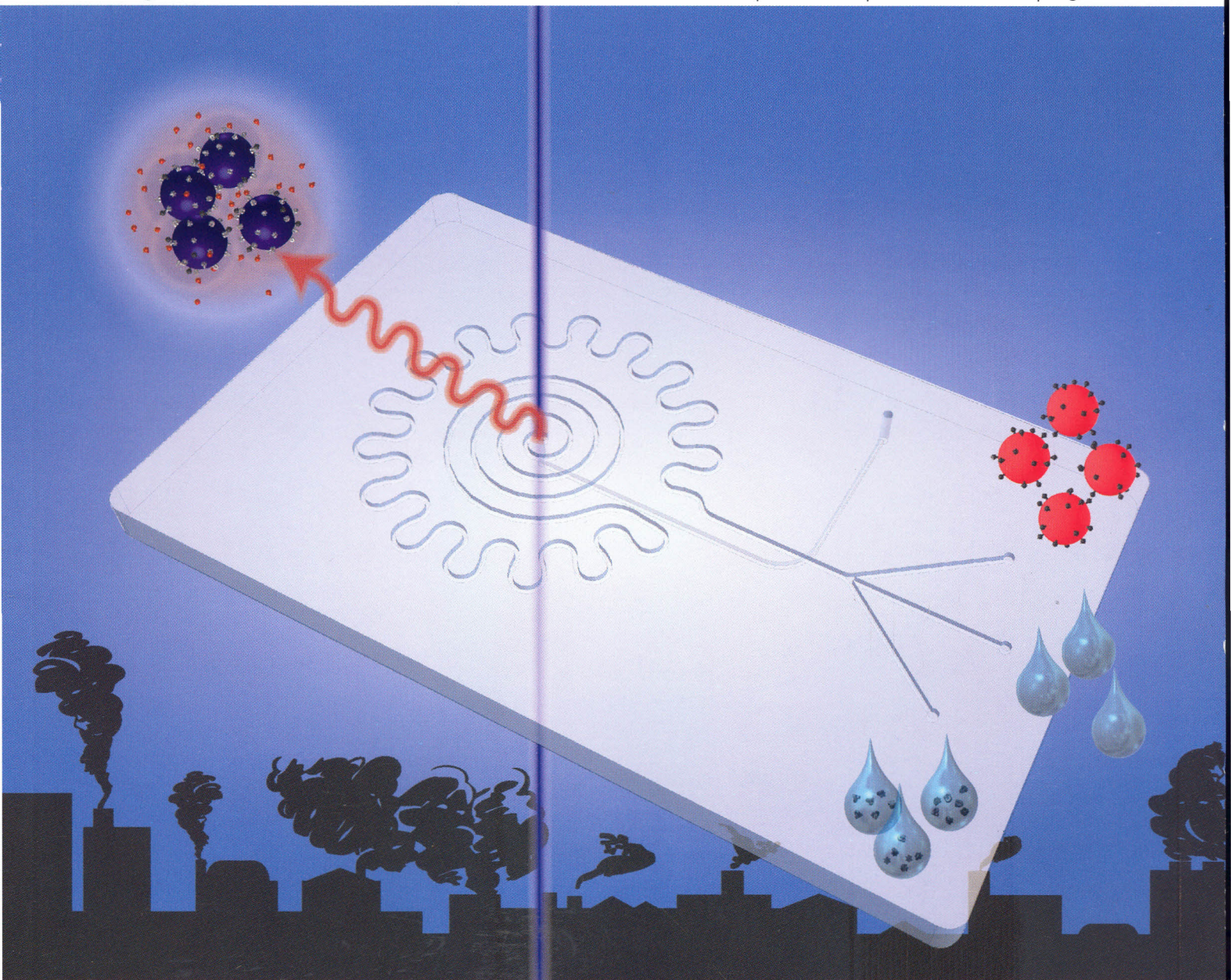

Themed issue: Focus on Scandinavia

ISSN 1473-0197

RSC Publishing

**PAPER**

Jörg P. Kutter *et al.*  
Gold nanoparticle-based optical microfluidic sensors for analysis of environmental pollutants



1473-0197 (2012) 12:22;1-Y

# Lab on a Chip

Miniaturisation for chemistry, physics, biology, materials science and bioengineering

[www.rsc.org/loc](http://www.rsc.org/loc)

RSC Publishing is a not-for-profit publisher and a division of the Royal Society of Chemistry. Any surplus made is used to support charitable activities aimed at advancing the chemical sciences. Full details are available from [www.rsc.org](http://www.rsc.org)

## IN THIS ISSUE

ISSN 1473-0197 CODEN LCAHAM 12(22) 4583–4930 (2012)



**Cover**  
See Jörg P. Kutter *et al.*,  
pp. 4651–4656. Image  
reproduced by permission  
of Jörg P. Kutter from  
*Lab Chip*, 2012, 12, 4651.



**Inside cover**  
See Vincent Aimez *et al.*,  
pp. 4683–4692. Image  
reproduced by permission  
of Vincent Aimez from  
*Lab Chip*, 2012, 12, 4683.

## THEMED ISSUE ARTICLES

### EDITORIAL

4601

#### Lab on a Chip: Scandinavia

Thomas Laurell and Jörg P. Kutter

Guest editors Thomas Laurell and Jörg P. Kutter highlight the contribution of Scandinavian research to micro- and nanofluidics.



### PROFILE

4603

#### Contributors to the Scandinavian issue 2012

*Lab on a Chip* profiles the contributors of the Scandinavian 2012 issue.



4605

**Single-cell electroporation using a multifunctional pipette**Alar Ainla, Shijun Xu, Nicolas Sanchez,  
Gavin D. M. Jeffries and Aldo Jesorka\*

We present a novel platform combination, using a multifunctional pipette to individually electroporate single-cells and to locally deliver an analyte while in their culture environment.

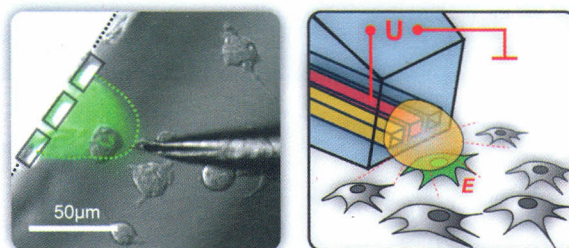

## PAPERS

4610

**Two-hundredfold volume concentration of dilute cell and particle suspensions using chip integrated multistage acoustophoresis**

Maria Nordin\* and Thomas Laurell\*

Two-dimensional acoustic standing wave focusing enables two-hundredfold cell concentration in continuous flow based cell handling.

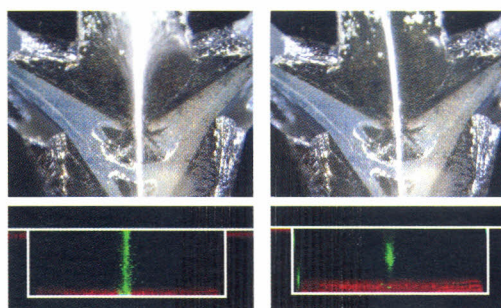

4617

**A numerical study of microparticle acoustophoresis driven by acoustic radiation forces and streaming-induced drag forces**Peter Barkholt Muller, Rune Barnkob,  
Mads Jakob Herring Jensen and Henrik Bruus\*

We present and analyze a numerical model of microparticle acoustophoresis including acoustic radiation forces, streaming flows, and boundary layers.

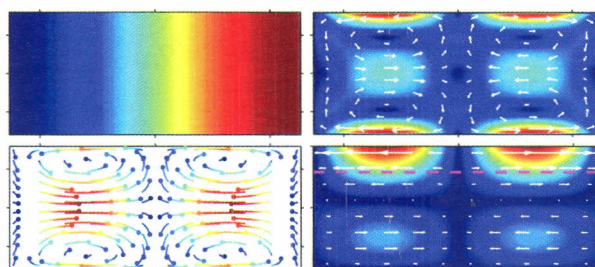

4628

**Centrifugally driven microfluidic disc for detection of chromosomal translocations**Anna Line Brøgger, Dorota Kwasny, Filippo G. Bosco,  
Asli Silahtaroglu, Zeynep Tümer, Anja Boisen and  
Winnie E. Svendsen\*

A centrifugal microfluidic platform with two valves in series that burst sequentially for proof-of-concept detection of chromosome translocations is demonstrated.

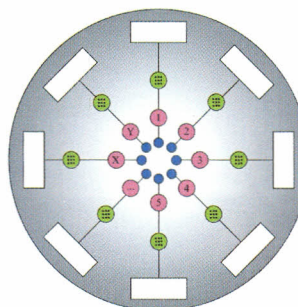

4635

### Solute transport on the sub 100 ms scale across the lipid bilayer membrane of individual proteoliposomes

Gabriel Ohlsson, Seyed R. Tabaei, Jason Beech, Jan Kvassman, Urban Johanson, Per Kjellbom, Jonas O. Tegenfeldt and Fredrik Höök\*

Microfluidics-assisted rapid (<10 ms) liquid exchange is used to determine membrane-protein (aquaporin) facilitated water transport in single liposomes.

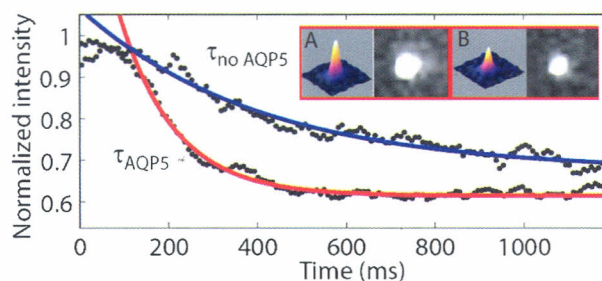

4644

### Inertial microfluidics in parallel channels for high-throughput applications

Jonas Hansson, J. Mikael Karlsson, Tommy Haraldsson, Hjalmar Brismar, W. van der Wijngaart and Aman Russov\*

High throughput inertial microfluidics in flows through single inlet, two outlet, multiple channel devices is introduced. The scalable multichannel devices are enabled *via* a novel, lithography defined, 3D PDMS interconnection fabrication method.

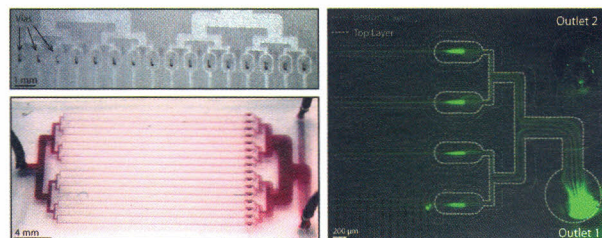

4651

### Gold nanoparticle-based optical microfluidic sensors for analysis of environmental pollutants

Josiane P. Lafleur, Silja Senkbeil, Thomas G. Jensen and Jörg P. Kutter\*

This report demonstrates that gold nanoparticle-based sensors offer an attractive pathway for the detection of pollutants on microfluidic devices.

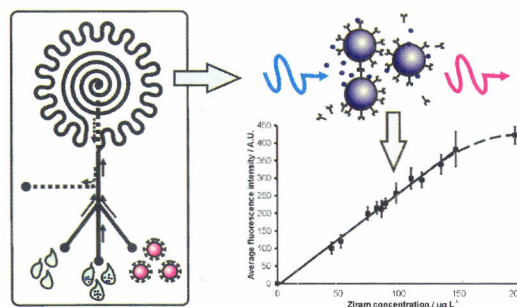

4657

### Liquid alloy printing of microfluidic stretchable electronics

Seung Hee Jeong, Anton Hagman, Klas Hjort, Magnus Jobs, Johan Sundqvist and Zhigang Wu\*

Cost-effective stencil printing, pick'n place assembly, and sealing demonstrated with a microfluidic stretchable electronics RFID tag.

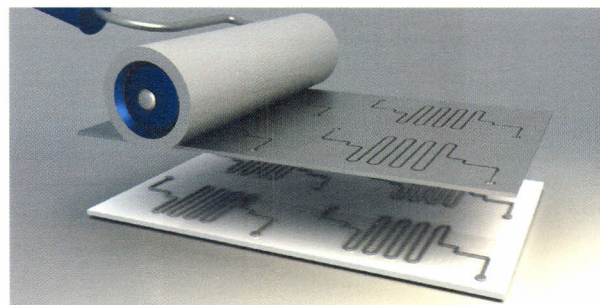

4665

**Research highlights**

Šeila Selimović, Mehmet R. Dokmeci and Ali Khademhosseini\*

Two-faced microreactors – Soft robots – Liquids as metamaterials.

## FOCUS

4667

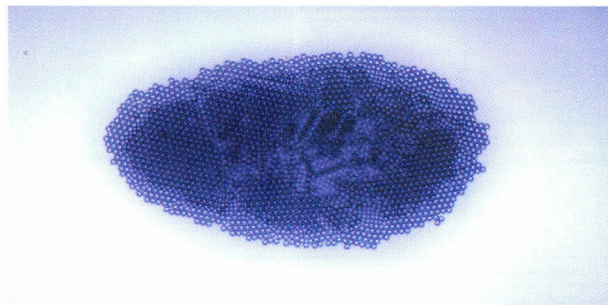
**Acoustofluidics 20: Applications in acoustic trapping**

Mikael Evander\* and Johan Nilsson

This part of the Acoustofluidics tutorial series reviews applications of acoustic trapping where forces in localised acoustic standing waves are used to manipulate and trap micrometer-sized particles and cells.

## TECHNICAL INNOVATION

4677

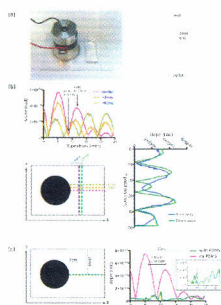
**Fragmentation of DNA in a sub-microliter microfluidic sonication device**

Qingzong Tseng, Alexey M. Lomonosov, Eileen E. M. Furlong and Christoph A. Merten\*

Fragmentation of DNA is an essential step for many biological applications including the preparation of next-generation sequencing (NGS) libraries.

## PAPERS

4683

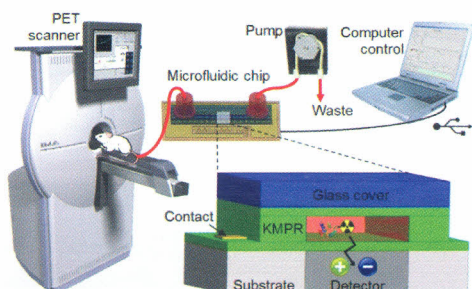
**Blood compatible microfluidic system for pharmacokinetic studies in small animals**

Laurence Convert, Frédérique Girard Baril, Vincent Boisselle, Jean-François Pratte, Réjean Fontaine, Roger Lecomte, Paul G. Charette and Vincent Aimez\*

A high efficiency microfluidic blood radioactivity counter was developed to monitor in real time the radioactivity contained in the blood of small animals for radiotracer developments in nuclear imaging.

4693

### Capture, isolation and release of cancer cells with aptamer-functionalized glass bead array

Yuan Wan, Yaling Liu, Peter B. Allen, Waseem Asghar, M. Arif Iftakher Mahmood, Jifu Tan, Holli Duhon, Young-tae Kim, Andrew D. Ellington and Samir M. Iqbal\*

Early detection and isolation of circulating tumor cells (CTC) can enable better prognosis for cancer patients.

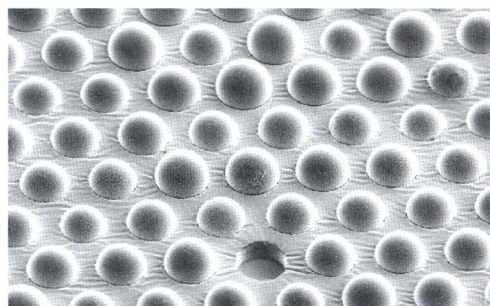

4702

### Low cost integration of 3D-electrode structures into microfluidic devices by replica molding

Benjamin Mustin\* and Boris Stoeber

We present a novel method for integrating 3D-electrode structures into microfluidic devices.

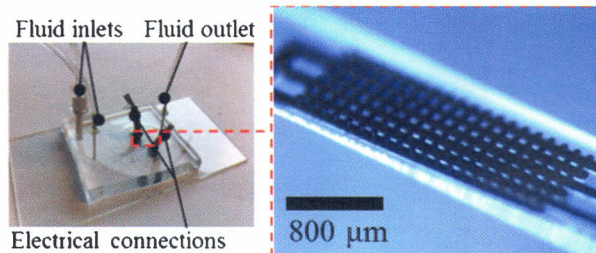

4709

### A microfluidic device with removable packaging for the real time visualisation of intracellular effects of nanosecond electrical pulses on adherent cells

C. Dalmay, M. A. De Menorval, O. François, L. M. Mir and B. Le Pioufle\*

Biodevices for the application and monitoring of ultra short (10 ns) and intense (up to  $280 \text{ kV cm}^{-1}$ ) electrical pulses on adherent cells.

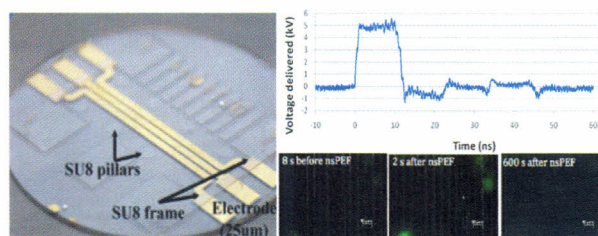

4716

### Programmable microfluidic synthesis of spectrally encoded microspheres

R. E. Gerver, R. Gómez-Sjöberg, B. C. Baxter, K. S. Thorn, P. M. Fordyce, C. A. Diaz-Botia, B. A. Helms and J. L. DeRisi\*

Spectrally encoded microspheres have many applications for biological assay miniaturization and multiplexing. Here, we present a novel microfluidic method for spectrally encoding microspheres by incorporating varying ratios of different lanthanide nanophosphors.

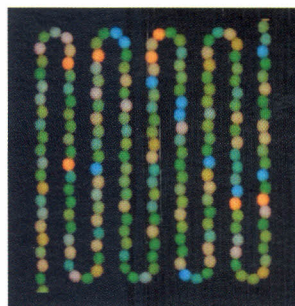

4724

### Single neuron capture and axonal development in three-dimensional microscale hydrogels

Yantao Fan, Feng Xu,\* Guoyou Huang, Tian Jian Lu and Wanli Xing\*

We used two-step lithography to achieve single cell capture with precise spatial control and high efficiency in a 3D GelMA hydrogel ring, which allows the investigation of autapses at the single cell level in a 3D fundamental neuroscience mechanism, especially regarding *in vivo* autapse functions.

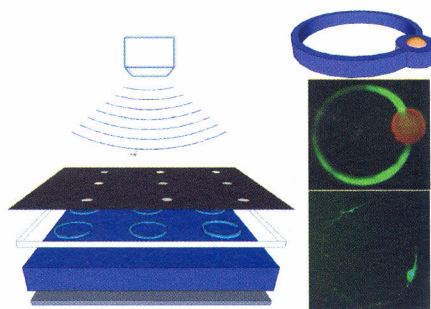

4732

### Vacuum-assisted cell loading enables shear-free mammalian microfluidic culture

Martin Kolnik, Lev S Tsimring and Jeff Hasty\*

On-chip transient vacuum in microfluidic channel evacuates air from culture chambers to enable efficient cell loading and shear-free perfusion culture.

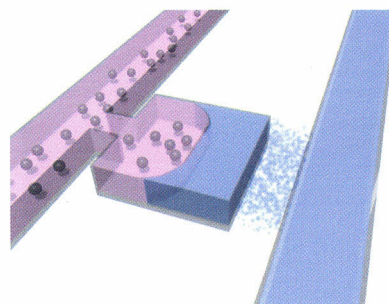

4738

### A low-cost, label-free DNA detection method in lab-on-chip format based on electrohydrodynamic instabilities, with application to long-range PCR

Mohamed Lemine Youba Diakit , Jer me Champ, Stephanie Descroix, Laurent Malaquin, Fran ois Amblard\* and Jean-Louis Viovy\*

This work proposes a new label-free method for recording DNA amplification, based on direct contact conductivity detection and wavelet analysis.

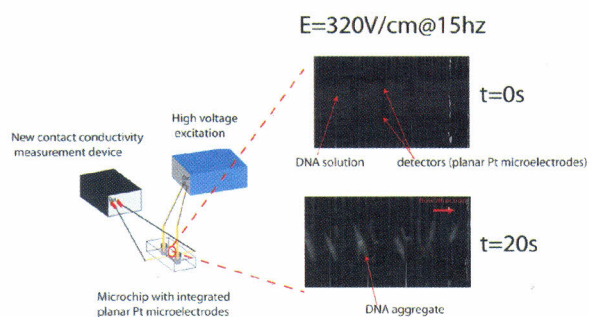

4748

### Highly sensitive microscale *in vivo* sensor enabled by electrophoretic assembly of nanoparticles for multiple biomarker detection

Asanterabi Malima, Salome Siavoshi, Tiziana Musacchio, Jaydev Upponi, Cihan Yilmaz, Sivasubramanian Somu, William Hartner, Vladimir Torchilin and Ahmed Busnaina\*

Highly sensitive microscale *in vivo* sensor that uses electrophoretically assembled functionalized nanoparticles for detection of multiple biomarkers.

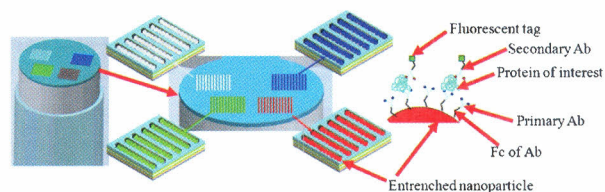

4755

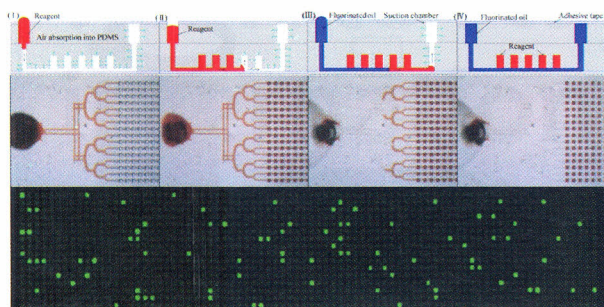

### Self-priming compartmentalization digital LAMP for point-of-care

Qiangyuan Zhu, Yibo Gao, Bingwen Yu, Hao Ren, Lin Qiu, Sihai Han, Wei Jin, Qinhan Jin and Ying Mu\*

A novel, valve-free and self-priming compartmentalization digital LAMP chip with appropriate air-tight packaging was developed for point-of-care testing.

4764

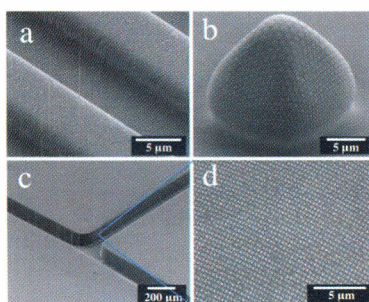

### 3D nanomolding for lab-on-a-chip applications

Bahador Farshchian, Sooyeon Park, Junseo Choi, Alborz Amirsadeghi, Jaejong Lee and Sunggook Park\*

We show a two-step molding technique, named 3D nanomolding, which allows the patterning of arbitrarily hierarchical multiscale structures, even nanostructures formed on vertical sidewalls of microfluidic channels.

4772

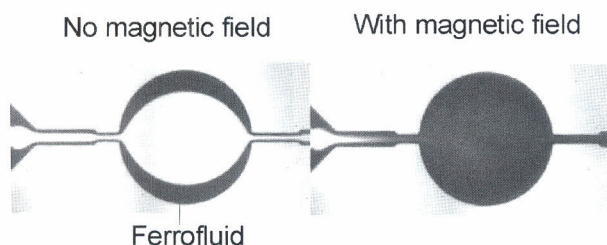

### Rapid magnetofluidic mixing in a uniform magnetic field

Gui-Ping Zhu and Nam-Trung Nguyen\*

This paper numerically and experimentally investigates magnetofluidic mixing in a circular chamber under an applied uniform magnetic field.

4781

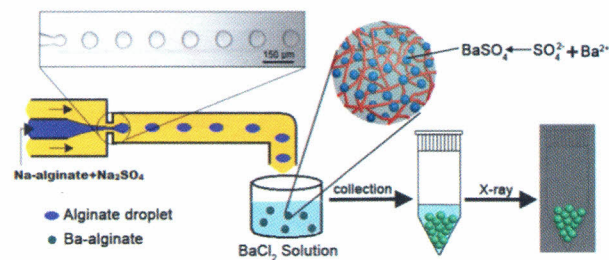

### Microfluidic one-step fabrication of radiopaque alginate microgels with *in situ* synthesized barium sulfate nanoparticles

Qin Wang, Di Zhang, Huibi Xu, Xiangliang Yang, Amy Q. Shen\* and Yajiang Yang\*

Droplet microfluidics is used to fabricate radiopaque microgels with *in situ* synthesized barium sulfate nanoparticles homogeneously distributed in the alginate carrier.



4787

**Cruise control for segmented flow**

Milad Abolhasani, Mayank Singh, Eugenia Kumacheva and Axel Günther\*

Capitalizing on the benefits of microscale segmented flows, e.g., enhanced mixing and reduced sample dispersion, so far requires specialist training and accommodating a few experimental inconveniences.

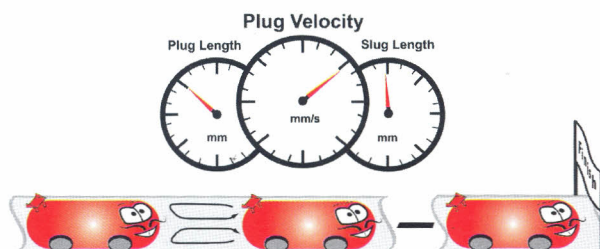

4796

**Silicon-on-glass pore network micromodels with oxygen-sensing fluorophore films for chemical imaging and defined spatial structure**

Jay W. Grate,\* Ryan T. Kelly, Jonathan Suter and Norm C. Anheier

Silicon-on-glass pore network microfluidic chips enable chemical imaging in transparent, oxygen-impermeable, water-wet chips etched with the precision of DRIE-silicon.

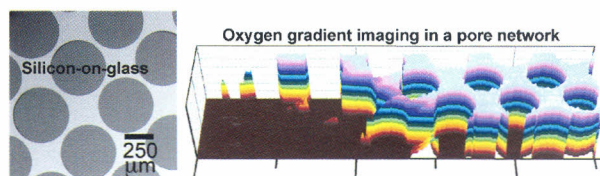

4802

**Gold on paper—paper platform for Au-nanoprobe TB detection**

Bruno Veigas, Jorge M. Jacob, Mafalda N. Costa, David S. Santos, Miguel Viveiros, João Inácio, Rodrigo Martins, Pedro Barquinha, Elvira Fortunato\* and Pedro Viana Baptista\*

*Gold on Paper*—new concept of lab-on-chip for TB diagnostics. A ready to use paper microplate combined with gold nanoparticle technology and smartphone data acquisition.

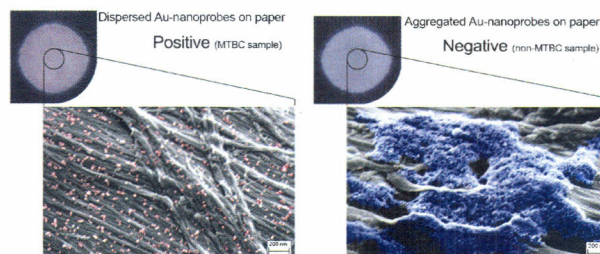

4809

**Pressure driven digital logic in PDMS based microfluidic devices fabricated by multilayer soft lithography**

Naga Sai Gopi K. Devaraju\* and Marc A. Unger

We present a novel, normally closed, static gain valve capable of modulating pressure signals in a fashion analogous to an electronic transistor and have used it to build complex fluidic logic circuits.

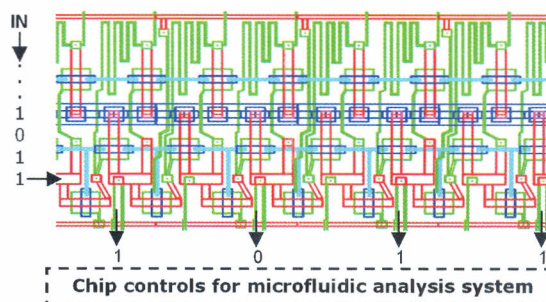

4816

### High-throughput optical injection of mammalian cells using a Bessel light beam

Helen A. Rendall,\* Robert F. Marchington, Bavishna B. Praveen, Gerald Bergmann, Yoshihiko Arita, Alexander Heisterkamp, Frank J. Gunn-Moore and Kishan Dholakia

Microfluidic optical injection of mammalian cells combining 2D hydrodynamic focusing with a Bessel light beam.

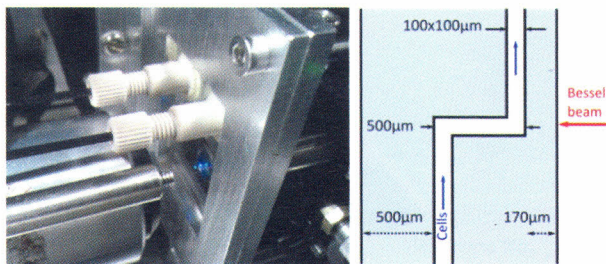

4821

### A portable and autonomous multichannel fluorescence detector for on-line and *in situ* explosive detection in aqueous phase

Yunhong Xin,\* Qi Wang, Taihong Liu, Lingling Wang, Jia Li and Yu Fang\*

A portable multichannel fluorescence detector has been developed for the sensitive detection and classification of nitroaromatics in aqueous phase.

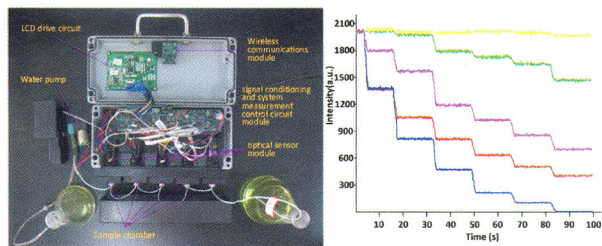

4829

### Growth and positioning of adipose-derived stem cells in microfluidic devices

Nitin Wadhawan, Harmandeep Kalkat, Kanmani Natarajan, Xiuli Ma, Sivakumar Gajjeraman, Saravanan Nandagopal, Ning Hao, Jing Li, Michael Zhang, Jixian Deng, Bo Xiang, Shadreck Mzengeza, Darren H. Freed, Rakesh C. Arora, Ganghong Tian\* and Francis Lin\*

We show that EGF guides the spatial growth and migration of adipose-derived stem cells and electric field mediates ASC orientation.

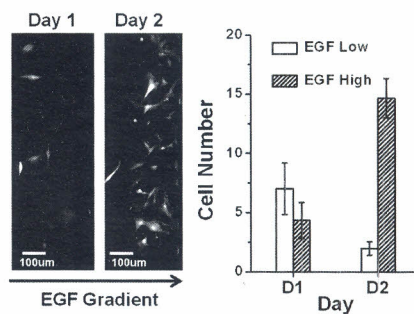

4835

### Studies of bacterial aerotaxis in a microfluidic device

Micha Adler, Michael Erickstad, Edgar Gutierrez and Alex Groisman\*

We report a series of experiments on aerotaxis of *E. coli* in a specially built experimental setup consisting of a computer-controlled gas mixer and a two-layer microfluidic device made of PDMS.

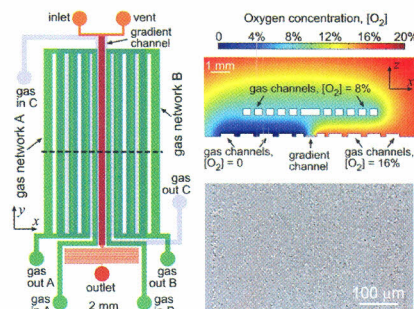

4848

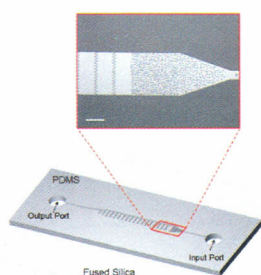

### Microfluidic extraction, stretching and analysis of human chromosomal DNA from single cells

Jaime J. Benítez, Juraj Topolancik, Harvey C. Tian, Christopher B. Wallin, David R. Latulippe, Kylan Szeto, Patrick J. Murphy, Benjamin R. Cipriany, Stephen L. Levy, Paul D. Soloway and Harold G. Craighead\*

We describe a microfluidic device for the extraction, purification and stretching of human chromosomal DNA from single cells.

4855

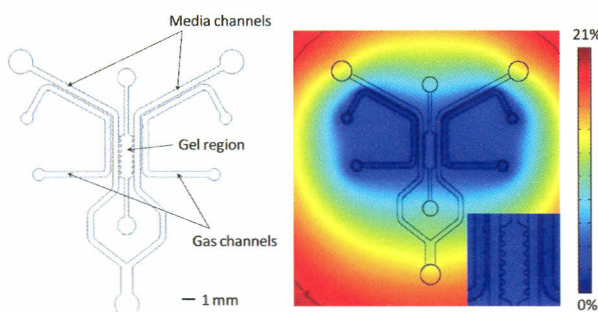

### A novel microfluidic platform for high-resolution imaging of a three-dimensional cell culture under a controlled hypoxic environment

Kenichi Funamoto,\* Ioannis K. Zervantonakis, Yuchun Liu, Christopher J. Ochs, Choong Kim and Roger D. Kamm\*

A microfluidic device for three-dimensional, real-time imaging of the cellular behaviours under hypoxia or gradients in oxygen gradient. Enhanced migration of human breast cancer was observed under hypoxia.

4864

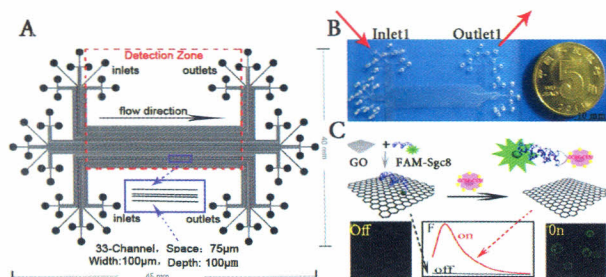

### Visual and high-throughput detection of cancer cells using a graphene oxide-based FRET aptasensing microfluidic chip

Lili Cao, Liwei Cheng, Zhengyong Zhang, Yi Wang, Xianxia Zhang, Hui Chen, Baohong Liu, Song Zhang\* and Jilie Kong\*

We demonstrate a multiplex microfluidic chip integrated with the GO-based FRET strategy to create a screening assay for tumor cells.

4870

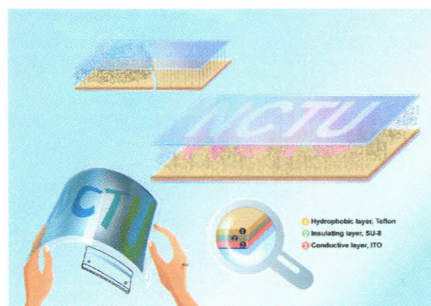

### Particle chain display – an optofluidic electronic paper

Shih-Kang Fan,\* Cheng-Pu Chiu, Ching-Hsiang Hsu, Shih-Chiang Chen, Li-Lin Huang, Yen-Hao Lin, Wei-Feng Fang, Jem-Kun Chen and Jing-Tang Yang

An optofluidic display is demonstrated by particle chain formation that dramatically changes transmittance and reflectance of the particle-based display medium.

4877

### Reactive deposition of nano-films in deep polymeric microcavities

Asif Riaz,\* Ram P. Gandhiraman, Ivan K. Dimov, Lourdes Basabe-Desmonts, Jens Ducr e, Stephen Daniels, Antonio J. Ricco and Luke P. Lee\*

Glassy surface formation in long polymeric microcavities of assembled devices through controlled diffusion of gas phase reactants created in plasma.

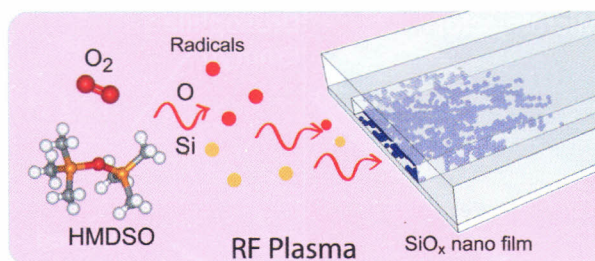

4884

### Prediction and control of number of cells in microdroplets by stochastic modeling

Elvan Ceyhan, Feng Xu, Umut Atakan Gurkan, Ahmet Emrehan Emre, Emine Sumeysra Turali, Rami El Assal, Ali Acikgenc, Chung-an Max Wu and Utkan Demirci\*

Manipulation and encapsulation of cells in microdroplets has found many applications in various fields such as clinical diagnostics, pharmaceutical research, and regenerative medicine.

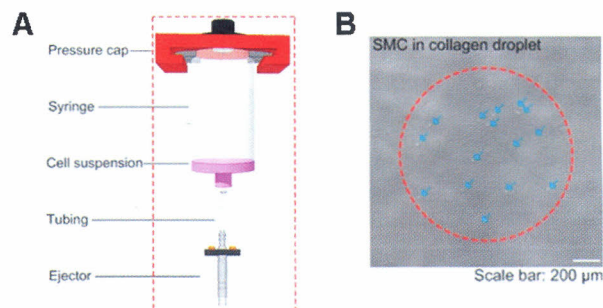

4894

### Syngas generation from *n*-butane with an integrated MEMS assembly for gas processing in micro-solid oxide fuel cell systems

A. Bieberle-H tter,\* A. J. Santis-Alvarez, B. Jiang, P. Heeb, T. Maeder, M. Nabavi, D. Poulikakos, P. Niedermann, A. Dommann, P. Murali, A. Bernard and L. J. Gauckler

Microreformer – functional carrier – assembly with high butane conversion rate and high H<sub>2</sub> and CO selectivity for micro-solid oxide fuel cell application.

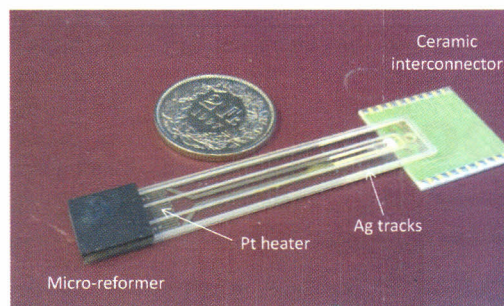

4903

### Patterns of molecular motors that guide and sort filaments

Beat Rupp and Fran ois N ed ec\*

Molecular motors can be immobilized to transport filaments and loads that are attached to these filaments inside a nano-device.

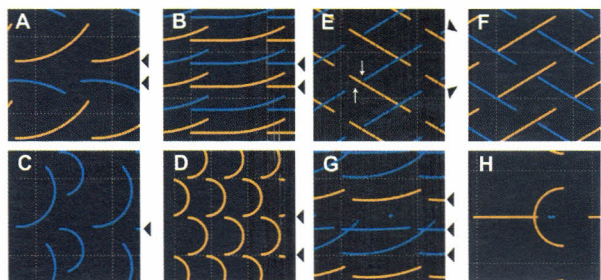

4911

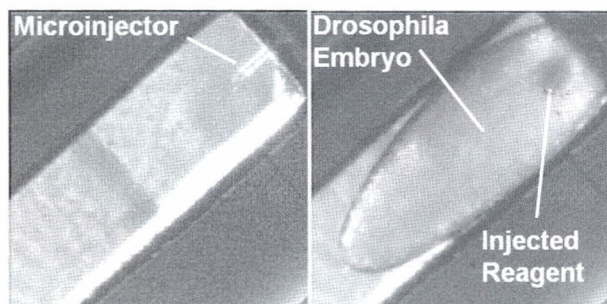

### Microfluidic system with integrated microinjector for automated *Drosophila* embryo injection

Daniel Delubac, Christopher B. Highley, Melissa Witzberger-Krajcovic, Joseph C. Ayoob, Emily C. Furbee, Jonathan S. Minden and Stefan Z...

Our fully automated, microfluidic system with integrated microinjector retrieves *Drosophila* embryos from an off-chip reservoir, injects embryos, and sends injected embryos to a second off-chip reservoir.

### METHOD

4920

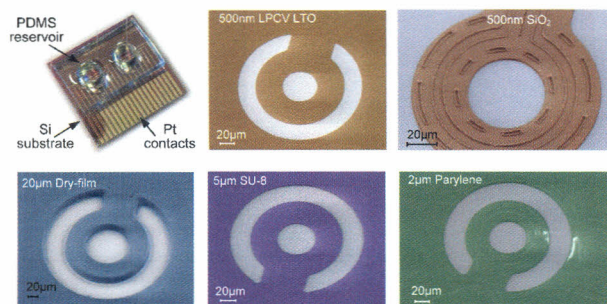

### A comparative study on fabrication techniques for on-chip microelectrodes

Yuksel Temiz, Anna Ferretti, Yusuf Leblebici and Carlotta Guiducci\*

This paper presents the reliability of fabrication techniques for the development of on-chip microelectrodes that are employed in aqueous solutions and/or subjected to chemical surface modification. Detailed fabrication processes for microelectrodes passivated with different materials, advantages and disadvantages of each technique, and statistical analysis of the measurement results are provided for comparison.

## Looking for free content?



Then register for an RSC Publishing personal account. Giving you access to all free content on the RSC Publishing platform, it includes:

- All content of our newest journals for the first 2 volumes
- Any articles that are part of a special free access promotion
- A sample chapter from each book in the RSC eBook Collection

and much more.

With your username and password you can access the free content any time, any place – all you need is internet access.

**So don't delay – register today.**